

1. FITS SOCKET HOUSING 640522.
2. ASSEMBLY CONFORMS TO AMP SOLDERABILITY SPEC. 109-11-3.
3. FOR USE WITH .063 THICK P.C. BOARD.
4. CONTACT IS PLATED OVERALL WITH .000050 NICKEL, THEN .000030 GOLD OVER CONTACT LENGTH INDICATED AND .000150 MATTE TIN-LEAD ON SOLDER TAIL END.
5. UL AND CSA LOGO LOCATED ON THIS SURFACE.
6. FOR USE WITH .120 THICK P.C. BOARD.
7. FOR USE WITH .093 THICK P.C. BOARD.
8. CONTACT IS PLATED OVERALL WITH .000050 NICKEL, THEN .000030 GOLD OVER CONTACT LENGTH INDICATED AND .000150 MATTE TIN ON SOLDER TAIL END.

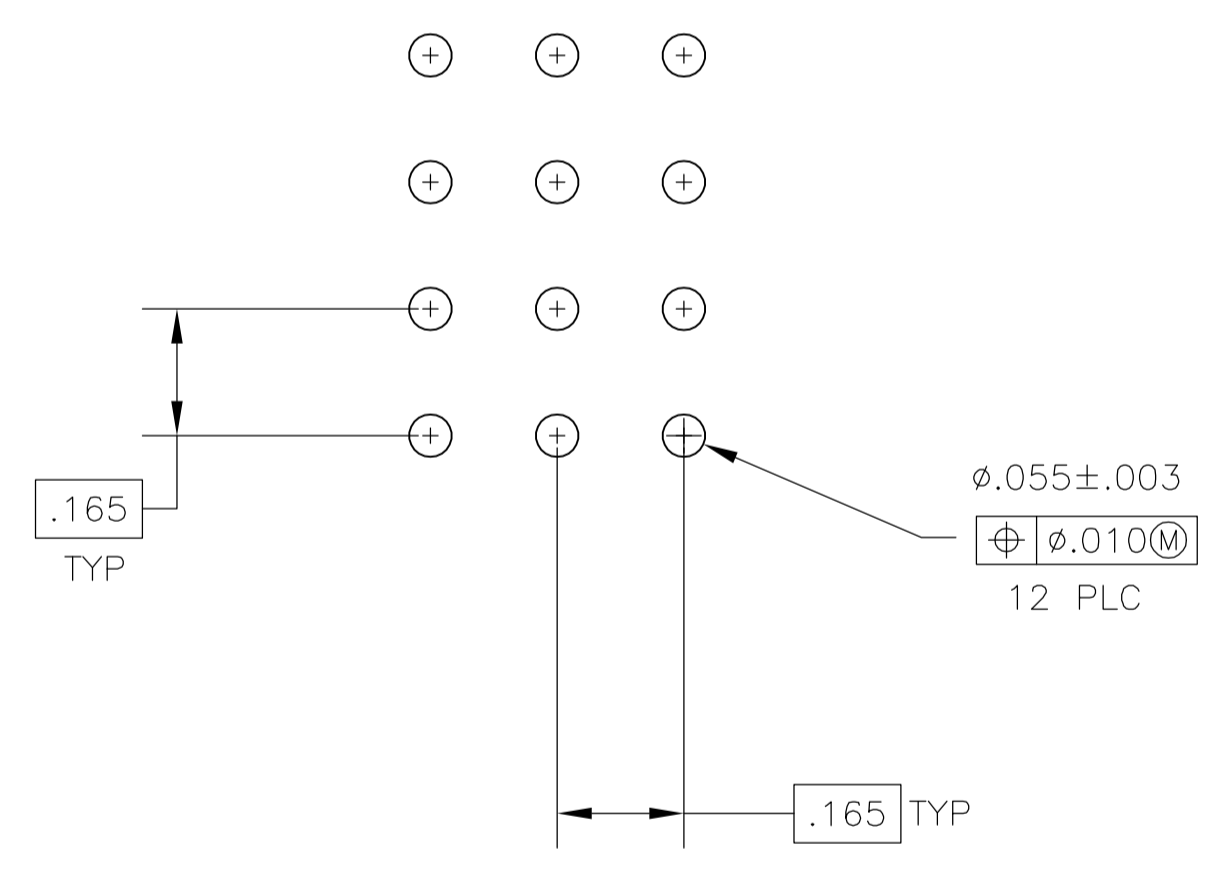

RECOMMENDED P.C. BOARD LAYOUT

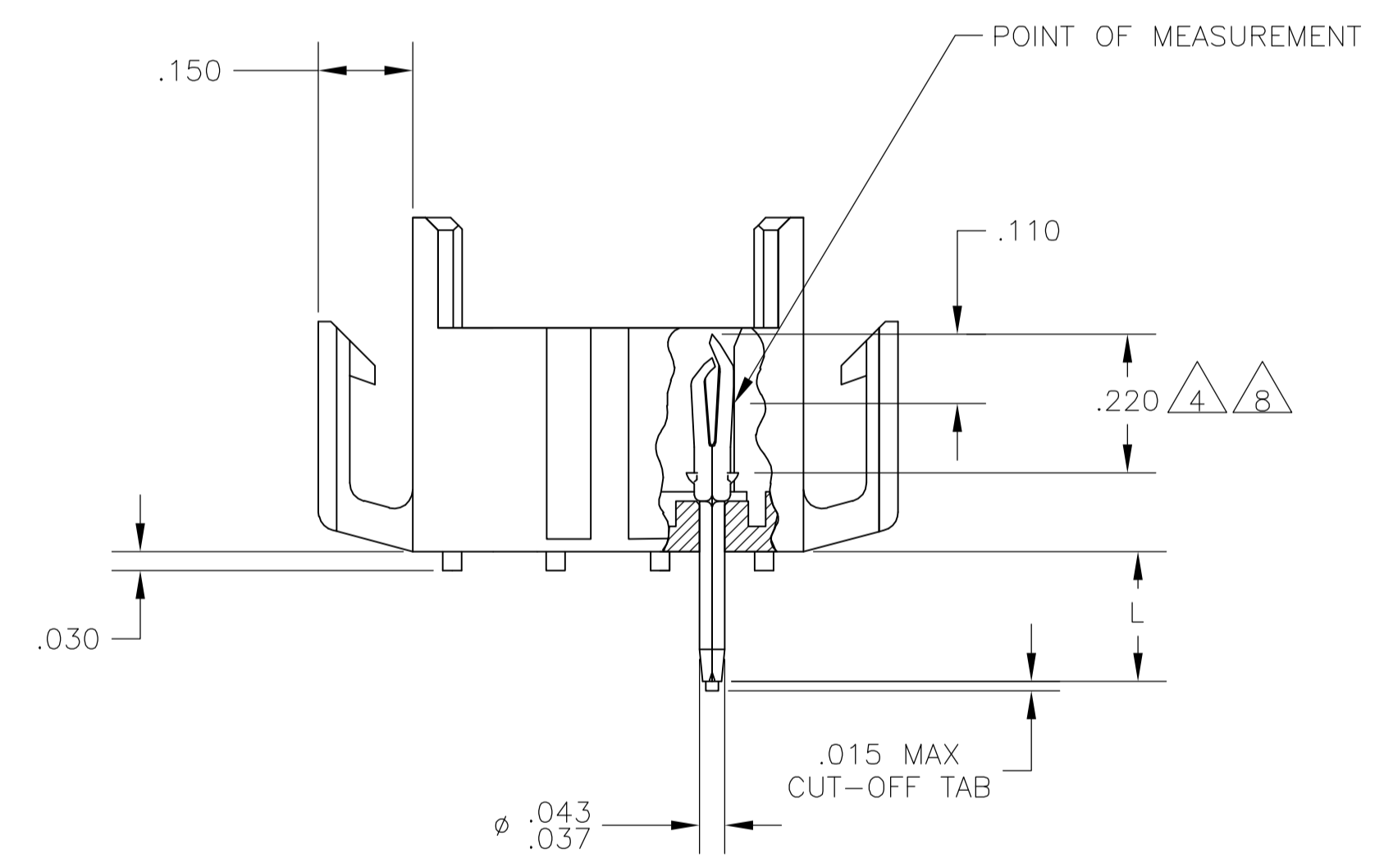

.180	7	BRICK RED	GOLD	8	2-640502-6
.210	6	BRICK RED	GOLD	8	2-640502-4
.150	3	BRICK RED	GOLD	8	2-640502-2
.180	7	BRICK RED	GOLD	4	640502-6
.210	6	BRICK RED	GOLD	4	640502-4
.210	6	BRICK RED	PRE-TIN		640502-3
.150	3	BRICK RED	GOLD	4	640502-2
.150	3	BRICK RED	PRE-TIN		640502-1
"L" +.010 -.020		HOUSING COLOR	PIN FINISH		PART NUMBER

.010	0.25	.055	1.40	.210	5.33	-	-
.008	0.20	.043	1.09	.180	4.57	-	-
.005	0.13	.037	0.94	.165	4.19	.785	19.94
.003	0.08	.030	0.76	.150	3.81	.620	15.75
.000050	0.00127	.020	0.51	.110	2.79	.530	13.46
.000030	0.00076	.015	0.38	.063	1.60	.220	5.59
IN	MM	IN	MM	IN	MM	IN	MM

CONVERSION TABLE

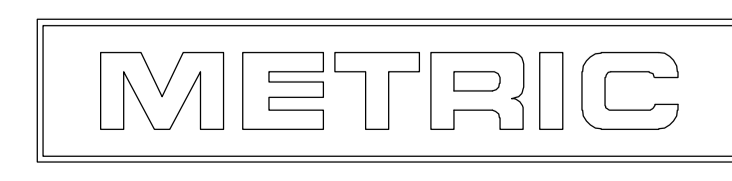

THIS DRAWING IS A CONTROLLED DOCUMENT.

DIMENSIONS: INCHES	TOLERANCES UNLESS OTHERWISE SPECIFIED:	0 PLC ± -	1 PLC ± -	2 PLC ± -	3 PLC ± .005	4 PLC ANGLES ± ± 0° 30'
--------------------	--	-----------	-----------	-----------	--------------	-------------------------

DWN J. HUFFMAN 28 APR 98	APVD T. REDDICK 28 APR 98	NAME T. REDDICK	DATE 28 APR 98
Tyco Electronics Corporation Harrisburg, PA 17105-3608		Tyco Electronics Corporation Harrisburg, PA 17105-3608	
APPLICATION SPEC PRODUCT SPEC		HEADER ASSEMBLY, PIN, 12 POSITION MR.	
MATERIAL HOUSING FLAME RETARDANT HOUSING UL 94V-0 PIN .008 PH BRZ.		FINISH SEE FINISH	
WEIGHT -		SIZE A1	
CUSTOMER DRAWING		SCALE 4:1 SHEET 1 OF 1 REV S	